

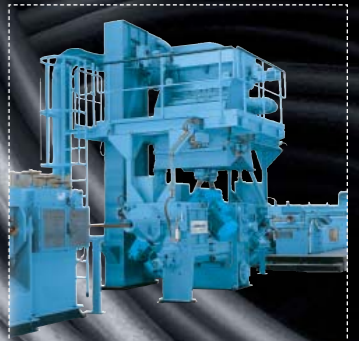

Subject to technical alterations • 03/10 • © Wheelabrator Group

Blast cleaning machines for wire and bar FL



DISA Industrie AG
Kasernenstrasse 1
CH-8184 Bachenbülach

T: +41 44 815 4000
F: +41 44 815 4001
E: zurich@wheelabratorgroup.com
www.wheelabratorgroup.com
www.disagroup.com

Noricor Group is the parent company of DISA and Wheelabrator.

wheelabrator
shaping industry

wheelabrator
shaping industry

Wire and bar descaling



Single strand drawing line with Wheelabrator blast cleaning

FL blast cleaning machines for longitudinal wire and bar descaling

Blast machines of the FL series are universal and efficient. Designed as 3, 4 or 6 blast wheel machines, they not only meet different capacity requirements, but can be ideally adapted to changing product runs. They are easy to integrate into modern drawing lines operating at speeds of up to 240 m/min or can be used as stand-alone machines for autonomous finishing.

With FL blast machines, wire, bar or sections with an envelope circle range of 5 to 130 mm diameter can be descaled by longitudinal

blasting. The machines are chosen according to the production program and the descaling speed: the best prerequisites for efficient concepts and customer specific solutions. Additional equipment such as reels, straightening units and driving devices, loading and unloading systems ensure a high degree of efficiency. Specific features are included to ensure that energy and abrasive are used to maximum effect. FL blast machines have proved themselves in hundreds of application sand in many cases operate around the clock.

From stand-alone machines to integrated solutions

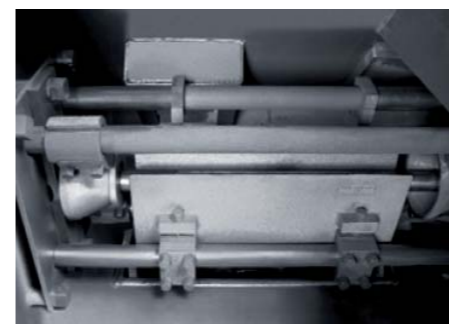

Shot blast chamber with abrasive stream guide plates and guide elements



The machine types for wire and bar descaling

For wire descaling:

The FL3, FL4 and FL6 machines are equipped with 3, 4 or 6 blast wheels and abrasive stream guide plates. Within seconds these guide plates can be adjusted to suit the cross section of the material being processed. This ensures maximum energy utilisation and the highest possible effectiveness of the abrasive. The guide plate system allows for smooth introduction and passage of smaller diameter wire.

For bar descaling:

Machines of this series with 4 or 6 blast wheels are especially designed for use in modern drawing lines with high drawing speeds. The guide and pressure rollers allow for smooth passage of the bars. Each transport roller is driven individually and is vertically adjustable.

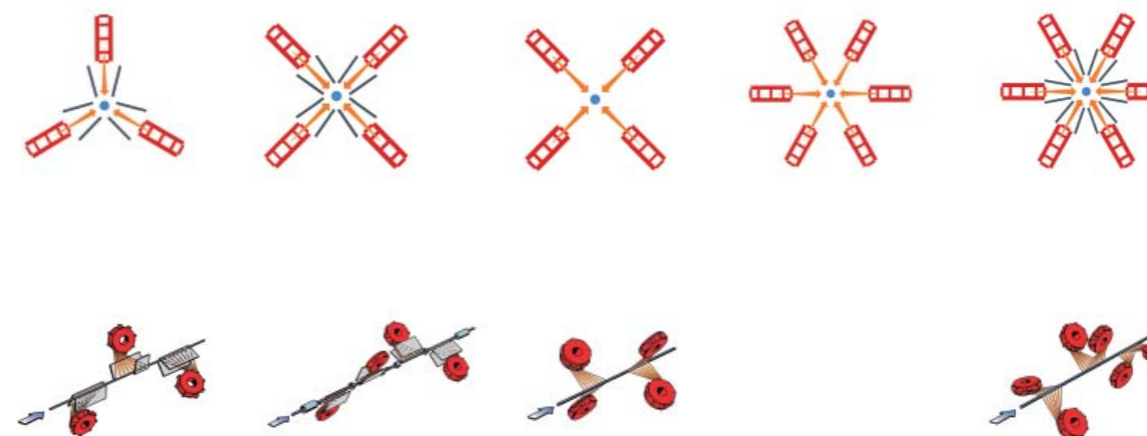

Design and operation



Shot blast machine with dust collector

The shot blast equipment consists of the following main groups:

- Transport system for wire and bar
- Shot blast machine
- Dust collector

The surfaces of commercially available wire and bar of different shapes and cross sections (round, square, hexagonal or flat bars) can be uniformly descaled by shot blasting. Guide elements allow for smooth passage of the wire and bar through the blast zone. The descaling speed is generally set to suit the type of scale, the material being processed and the degree of surface cleanliness desired. The abrasive material is recovered by an efficient separation system in which scale, dust and under-sized abrasive are eliminated.

Safe and reliable operation

All components exposed to wear are made of high-quality wear-resistant material. Functional components, such as blast wheels, separators, bucket elevators and feed elements are of standard industry-proven design. Multiple guide elements ensure controlled passage of the products through the blast zone and a safe and continuous operational sequence. By means of driving and pre-straightening units efficient descaling of the front and rear ends is provided.

A work environment with advanced pollution control, simple maintenance

The environment-friendly operation of a single strand shot blast machine prevents hazards to operating personnel and damage to equipment and buildings from toxic and caustic fumes. Effective dust collection and an abrasive circulation system fully integrated into the machine provide advanced ecological standards for the work environment.

High sustainability, reduced production costs



Shot blast chamber



Pressure-rollers guide the workpiece



Blast cleaning machine for longitudinal wire descaling

Brush seals at the workpiece entrance and exit prevent the escape of abrasive. The compact design of the machine requires a minimum of safety elements. Replacement of wear parts is fast and simple. The blast housing is made of manganese hard steel and is equipped with wear plates. All main operating elements such as blast wheels, bearings and drives are neatly arranged for easy inspection. Liners and wear plates are easily accessible through large service doors.

Reduced production costs

Integration of the shot blast process into an automatic production line will help to reduce operating costs. The installation of the compact machine at floor level facilitates its integration into existing lines. This results in an uninterrupted and controllable production flow and maximum utilisation of the blast wheel capacity in the descaling operation. Remote control of the abrasive throughput permits easy adaptation of the shot blast process to changing production requirements

and prevents waste of abrasive. High-quality heat treatment or hardening ensure unmatched durability of original wear parts. These features are the best prerequisites for long service life and a minimum of downtime for maintenance purposes. The specifically designed air cleaning system and an efficient dust collector ensure absolutely dust-free workpieces thus considerably reducing wear on the wire drawing dies.

Single strand wire descaling system

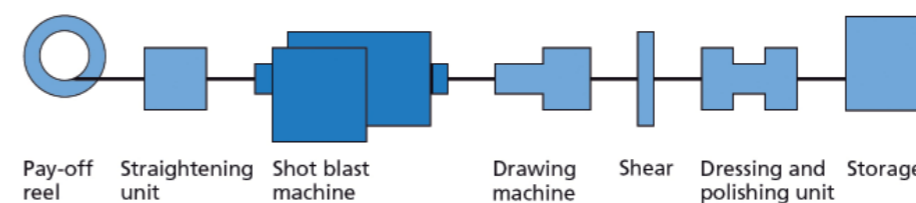

Single strand bar descaling system

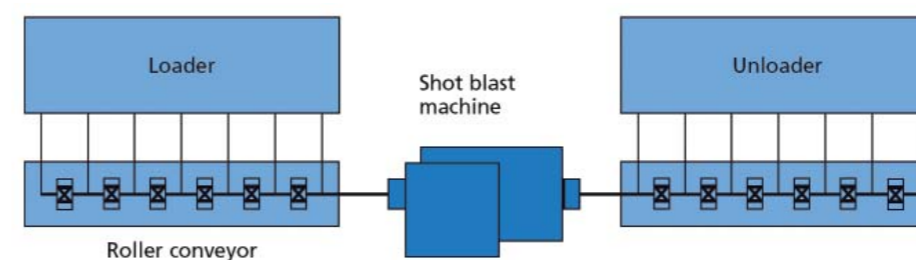

Blast wheels



FL blast cleaning machines: compact, space-saving design, ease of maintenance



Multistrand bar descaling machine

Wheelabrator blast wheels are renowned for high capacity and maximum energy efficiency. These blast wheels come in various power ratings, giving a high degree of flexibility. The amount of abrasive can be adjusted from the operator's panel. The abrasive is mechanically pre-accelerated and delivered to the blast wheel in a continuous stream. This ensures optimal utilisation of the power from the drive motors. Highly wear resistant material ensures maximum service life of the blast wheel. Unique design features allow for rapid and simple replacement of wear parts.

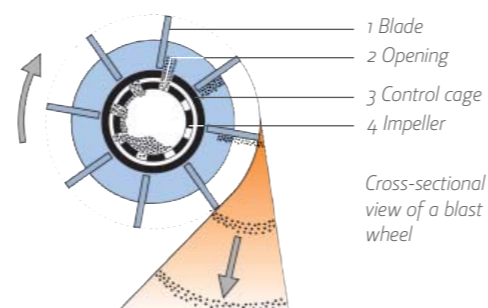

Technical data

Model overview	Wire		Bar		Bar	
	FL 3-15/38 FL 3-22/38	FL 3-30/55 FL 3-37/55	FL 4-30/55 FL 4-37/55	FL 6-30/55	FL 4-30/110 FL 4-37/110	FL 6-30/130
Area of application	●○■	●○■	●○■■	●○■■	●○■■	●○■■
Diameter, enveloping circle (mm)	38	55	55	55	110	130
Blast wheels, number	3	3	4	6	4	6
Drive capacity per wheel (kW)	15/22	30/37	30/37	30	30/37	30
Abrasive throughput (ca.kg/min)	3 x 180 / 3 x 300	3 x 425 / 3 x 500	4 x 425 / 4 x 540	6 x 425	4 x 425 / 4 x 540	6 x 425
Dimensions						
Length A (mm)	3250	4240	5240	7900	5300	6900
Width B (mm)	2850	3100	3415	4670	3340	4670
Height C (mm)	4355	4750	5530	5730	5230	5730
Height of passage D (mm)	1000	1000	1200	1200	1200	1200
Special features						
Wire/bar guidance	Sealing bushes		Sealing bushes		Sealing bushes	
Blast guide plates	3 pairs		4/6 pairs		-	
Wire guides	3 pieces		3 pieces		-	
Blasting principle						

