

M1 BASIC – The cost efficient alternative for processing single components or small work piece batches



Surface finishing



Plastic



Metal

Features & benefits

- Easily adaptable to different finishing tasks
- Multiple work pieces can be finished simultaneously in different processes
- Compact machine with integrated process water recycling and process control
- Cost effective operation

Technical highlights

As a highly economical entry-level machine the compact and user-friendly M1 Basic machine can be easily integrated into your manufacturing line as a completely self-contained system. This equipment solution also distinguishes itself by a compact design and ease of operation. It is ideal for surface

smoothing and polishing of 3D printed components made from metal or plastic. Whether you must process individually printed components or small work piece batches - the M1 Basic guarantees perfect and repeatable finishing results.

Equipment layout

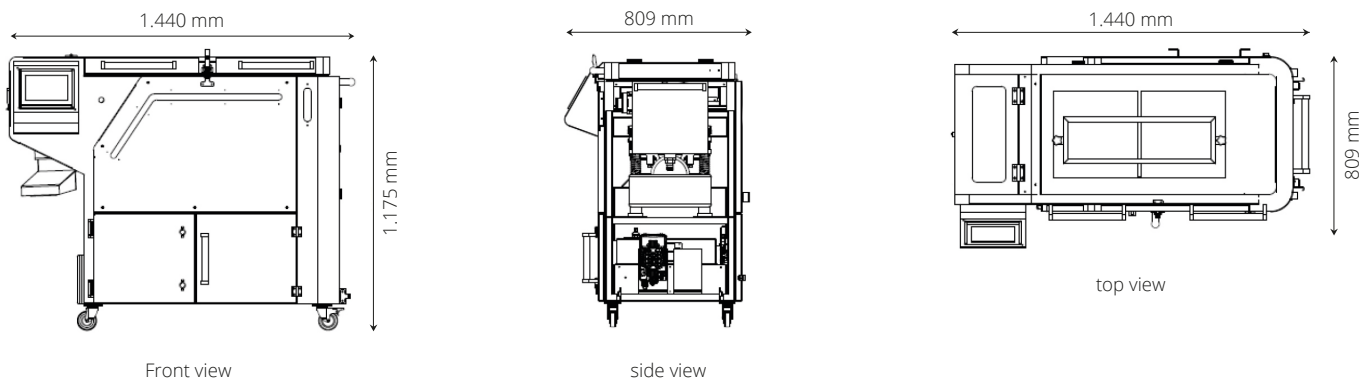

Equipment specifications

Technical data	Electrical connection
Inside dimensions processing bowl: 210 x 530 mm (W x L)	Supply voltage: 230 V, 50 Hz, 1 Ph N/PE
High frequency processing with 3,000 RPM	Control voltage: 24 V DC
Drive power: 0.65 kW	
Infinitely adjustable process water recycling pump 0 - 24 l/h	
Noise level below 75 dB(A)	
Ambient temperature: +5 to + 40 °C	

Possible work piece dimensions (mm; L x W x H)

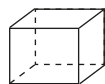

Minimum size: 5 x 5 x 5
Maximum size: 500 x 150 x 130

